

Importateur
B&K Lumitec
2 rue Alfred Kastler
Zone industrielle
67850 HERRLISHEIM
www.bklumitec.com
info@bklumitec.com



Stage Profile Zoom

17-50° 200W DMX RGBW



Anleitung

1. Inhalt



Stage Profile Zoom



Cordon secteur



Manuel

2. Maße

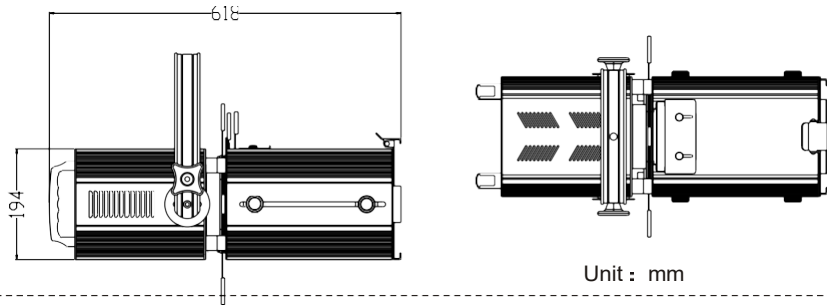

Unit : mm

3. Verkabelung

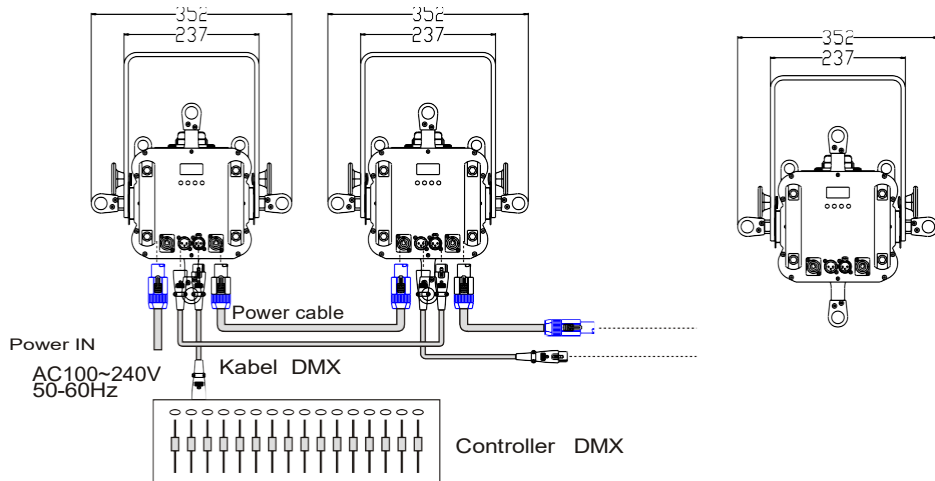

10. Notes

Blank area with horizontal dashed lines for notes.

9. Funktionen

Mode DMX

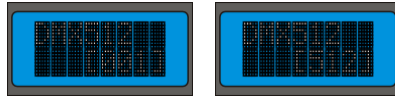
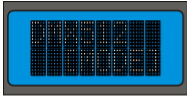

Adresse DMX : 001-512

DMX 9 Kanäle

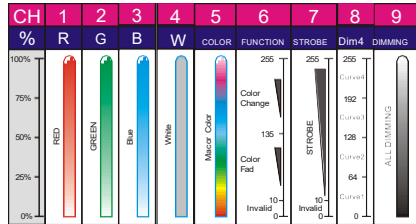

Mode Dimmer

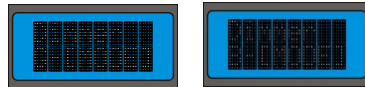

Leuchtkraft : 0001-4096

Mode Strobe

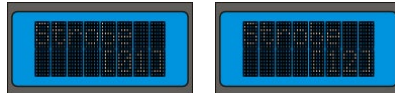
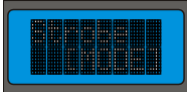

Strobe-Geschwindigkeit : 01-12

Mode Fade

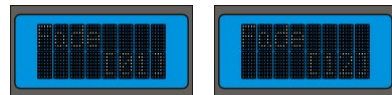

Fader-Geschwindigkeit 01-12

Mode Auto

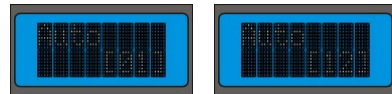
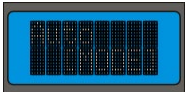

Automatische:Geschwindigkeit 01-12

Mode Master/Slave :

1. Master : Mode Dimmer, Mode Strobe, Canaux DMX 2.Slave : DMX001 (siehe unten)

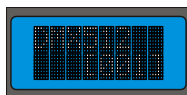

4. Photometrische Daten

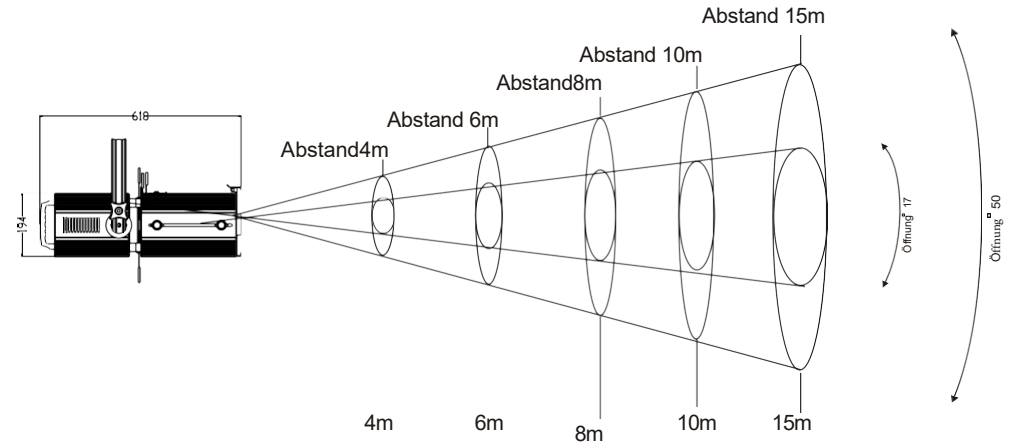

Leuchtkraft / Lux	R	560	275	202	135	110	Öffnung 17
	G	750	390	250	240	148	
	B	950	495	320	308	175	
	W	1010	490	332	325	176	
Durchmesser des Strahls / cm		120	179	240	299	449	
Leuchtkraft / Lux	R	230	110	75	60	53	Öffnung 50
	G	320	170	103	80	75	
	B	338	175	105	95	80	
	W	335	170	101	91	85	
Durchmesser des Strahls/ cm		225	378	429	631	946	

5. Installation

Hängend

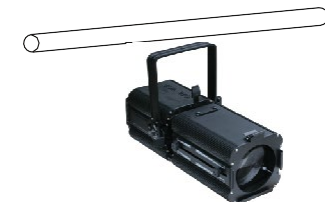

6. Beschreibend

Lichtquelle	1x LED COB RGBW 4en1 200W	
Optisches System	Öffnung: 17-50°	
Bedienung	DMX 9 canaux; manuel	
Verbindung	Powercon In & Out; DMX XLR 3 points In & Out	
Spannung	AC 100-240V 50/60Hz	
Leistung max.	200W	
Maße	61.5X28X21.5cm	Gewicht 11Kg

7. Systemsteuerung

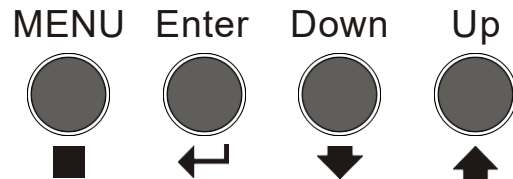
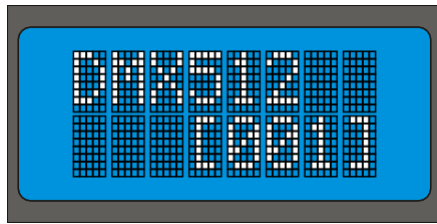

- Parameter-Tasten
- Press MENU ----> Erstes Menü ---->
- Press Enter ----> Zweites Menü ---->
- Press Down&Up Werte ändern ---->
- Press Enter MENÜ Verlassen ---->
- Press MENU ----> Menu weiter

8. Menu

