

/SMOKEBUBBLE BLASTER®

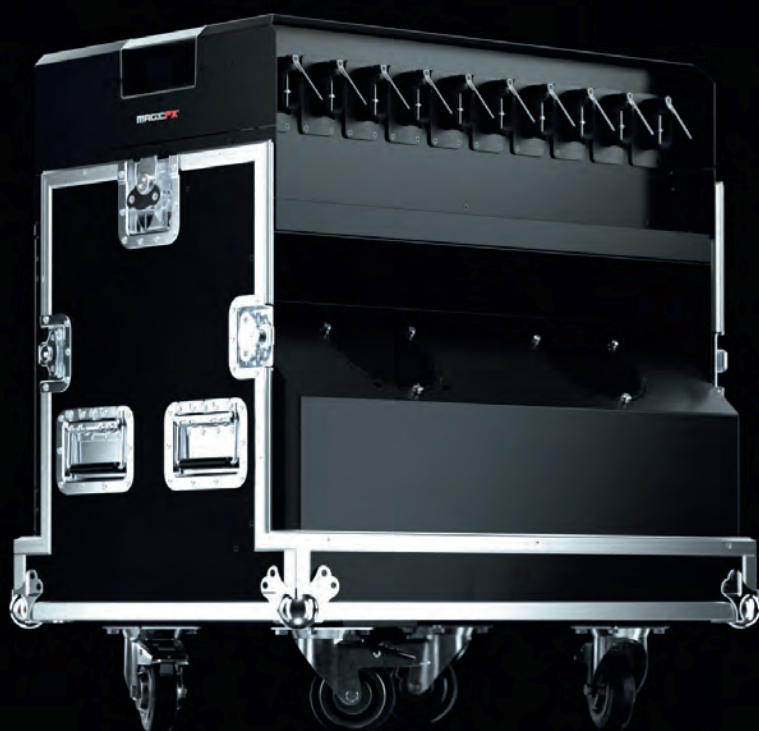

DISCLAIMER

⚠ WARNING

Read this manual carefully before installing and/or using this product. Failure to read the manual and to follow the printed instructions may lead to personal injury and/or damage to the product.

© 2018 MAGICFX®
All rights reserved.

Nothing from this publication may be copied, reproduced and/or published by means of printing, photocopying or by any other means, without the prior written approval of MAGIC FX.

MAGIC FX reserves the right to modify specifications stated in this manual.

TRADEMARKS

Any brand names mentioned in this manual are registered trademarks of their respective owners.

LIABILITY

MAGIC FX accepts no liability for claims from third parties arising from unauthorised use, use other than that stated in this manual, and use other than in accordance with the General Conditions registered at the Chamber of Commerce.

Refer further to the General Conditions. These are available on request, free of charge.

Although considerable care has been taken to ensure a correct and suitably comprehensive description of all relevant components, the manual may nonetheless contain errors and inaccuracies.

Should you detect any errors or inaccuracies in the manual, we would be grateful if you would inform us. This helps us to further improve our documentation.

TABLE OF CONTENTS

Disclaimer	3
Trademarks	3
Liability	3
Foreword	5
Language	5
Revision table	5
1 Meet the MAGICFX® SMOKEBUBBLE BLASTER!	6
1.1 Main parts	7
1.2 Technical data	8
1.3 Product identification	8
1.4 FX Fluids	9
1.5 Manual mode	9
1.6 DMX control	9
1.7 Display panel	10
1.8 RDM capability	12
2 Bubble safely!	13
2.1 General safety rules	13
2.2 Indoor use	13
2.3 Rigging	13
2.4 Safety symbols	14
2.5 Precautions for operation	14
3 Let's bubble!	15
3.1 Install the machine	15
3.2 (Re)place the jerrycan with bubble fluid	17
3.3 (Re)place the jerrycan with smoke fluid	18
3.4 Configure Manual mode	20
3.5 Bubble in Manual mode	20
3.6 Connect power and setup DMX	21
3.7 Setup multiple machines in a sequence with DMX	22
3.8 Bubble with DMX	22
3.9 Clean up	23
3.10 Clean the launch fans (when needed)	28
4 Maintenance	29
5 Troubleshooting	29
6 Correct disposal	29
7 EC Declaration of Conformity	30

FOREWORD

Congratulations! You have bought a great new product from MAGIC FX.

This manual contains all information required for the intended use of the equipment. Deviation from the described intended use can result in a hazardous situation and/or property damage.

This manual includes notes and warnings on safe operation of the equipment. These notes and warnings are accompanied by the following icons. Read them attentively!

⚠ DANGER	Indicates a hazardous situation that, if not avoided, will result in death or serious injury. This signal word is to be limited to the most extreme situations.
⚠ WARNING	Indicates a hazardous situation that, if not avoided, could result in death or serious injury.
⚠ CAUTION	Indicates a hazardous situation that, if not avoided, could result in minor or moderate injury.
NOTICE	Indicates information considered important, but not hazard-related (e.g. messages relating to property damage).

LANGUAGE

This document contains the original instructions in English. In case you require other languages please contact MAGIC FX.

REVISION TABLE

Document nr	Revision	Date	Description	Authored by	Checked by
PART01224	01-00	29-08-2017	Initial release	TFR	TVA
PART01224	01-01	01-03-2018	Revised jerrycan lid	TFR	TVA

1 MEET THE MAGICFX® SMOKEBUBBLE BLASTER!

The MAGICFX® SMOKEBUBBLE BLASTER is a special effects machine that launches bubbles (optionally filled with smoke) into the air with a capacity of 6.000 bubbles a minute.

The MAGICFX® SMOKEBUBBLE BLASTER pumps bubble fluid from a jerrycan to the bubble heads. The bubble fluid leaves a bubble head through the double-walled exterior. A servo-driven wiper frequently wipes the head. This creates a small membrane on the head. The air from an overpressurized chamber behind the bubble heads blows the air into the membrane. This creates a trail of bubbles from the bubble head.

A pair of fans blow air into the chamber behind the bubble heads. This creates the overpressure conditions in the chamber. Another pair of fans is positioned underneath the heads. The controllable air flow from the fans will launch the bubbles high into the air.

Optionally smoke fluid is pumped from a jerrycan, vaporized into smoke by two heating elements and led to the bubble heads. The smoke output is located inside the bubble head. The smoke from the output is mixed with the air that makes the bubbles.

Unused bubble fluid from the bubble heads will fall into a drip tray. A drain and connected hose transports the remains back into the jerrycan with bubble fluid.

The MAGICFX® SMOKEBUBBLE BLASTER is outfitted for operation:

- in Manual mode with multiple options (e.g setting a timer and the output distance);
- with DMX and optionally RDM;
- in sequence with multiple machines.

1.1 MAIN PARTS

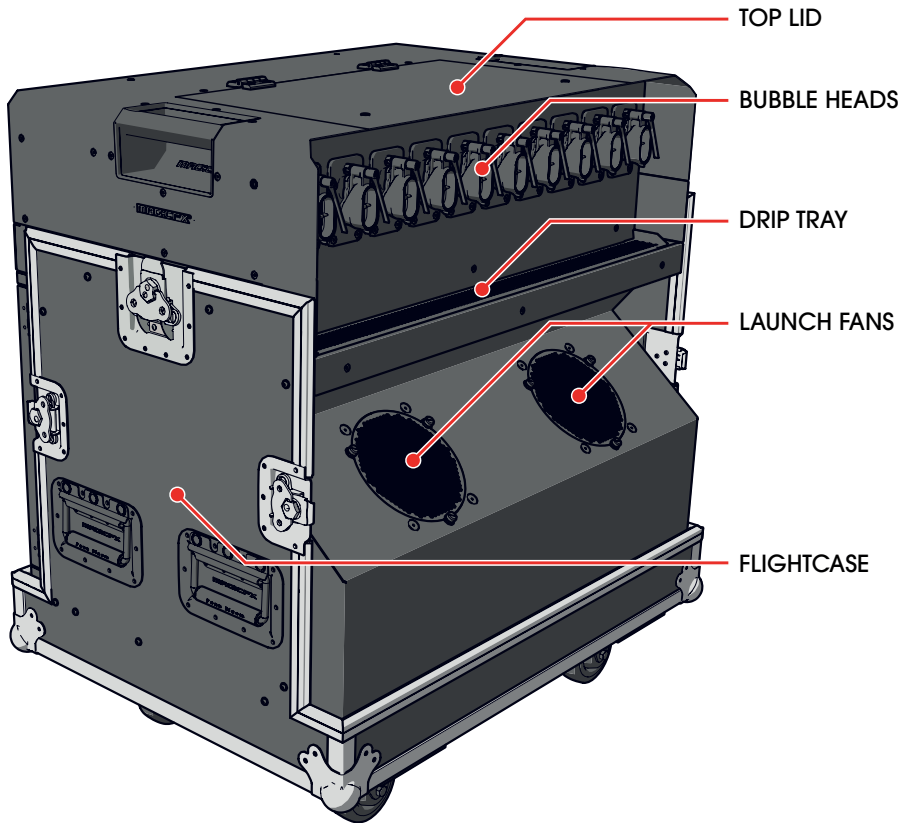

Front perspective view

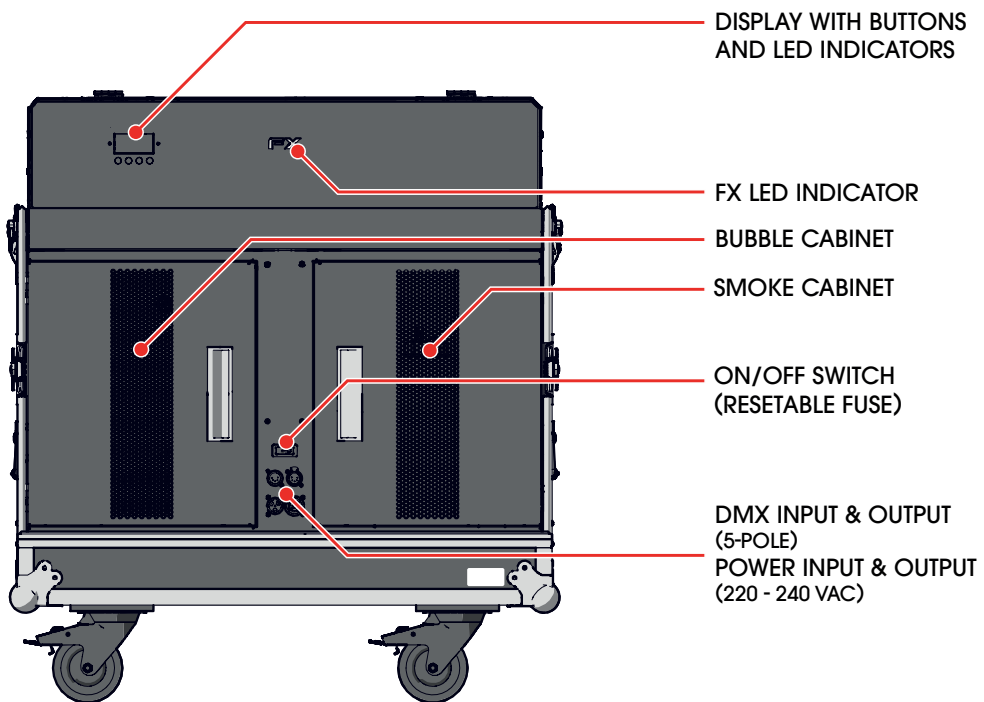

Back view

1.2 TECHNICAL DATA

Product	Product Name	MAGICFX® SMOKEBUBBLE BLASTER	
	Product Code	MFX1603	
	Product Type	BUBBLE FX	
Main Dimensions	Length (mm/in)	800	31,5
	Width (mm/in)	600	23,6
	Height (mm/in)	920	36,2
Weight	Weight (kg/lb)	92	202,8
Environment	Minimum Temperature (°C/°F)	5	41
	Maximum Temperature (°C/°F)	50	122
	Humidity (Relative)	20% to 90% (non condensing)	
	IEC 60529 (IP) Rating	IP12	
Electrical	Voltage Input (Vac)	220 - 240 Vac	
	Voltage Frequency	50 Hz	
	Power Consumption (Vac)	600 W	
	Power Connector (Vac)	Neutrik® powerCON TRUE1 (in & out)	
Controlling	Control Options	DMX / Manual / Timer	
	Control Protocols	DMX512-A (ANSI E1.11) / RDM (ANSI E1.20)	
	Control Connectors	Neutrik® 5 pole male / female XLR	
Configuring	Configure Options	On Device & RDM	
Usage	Consumable(s)	MAGICFX® BUBBLE FLUID MAGICFX® SMOKE FLUID	
	Consumable Consumption	MAGICFX® BUBBLE FLUID: 8,5 L/h MAGICFX® SMOKE FLUID: 0,275 L/h	

Technical data

1.3 PRODUCT IDENTIFICATION



Type plate

1.4 FX FLUIDS

The MAGICFX® SMOKEBUBBLE BLASTER uses bubble fluid and smoke fluid from MAGIC FX to create smoke bubbles. The fluids are delivered in jerrycans. The 20 liter jerrycan with bubble fluid is placed and connected in the bubble cabinet, see Section 3.2. The 5 liter jerrycan with smoke fluid is placed and connected in the smoke cabinet, see Section 3.3. The sheet metal interiors of the cabinets hold the jerrycans in place.

Do not use other fluids than those that are approved and supplied by MAGIC FX, see following table.

Code	Type of fluid	Volume
MFX3027	MAGICFX SMOKEBUBBLE BLASTER® - SMOKE FLUID	5 liter
MFX3003	MAGICFX® PRO BUBBLE FLUID - READY TO USE	20 liter

Approved FX Fluids

1.5 MANUAL MODE

In Manual mode the machine starts bubbling instantly when switched on. In the menu on the display you can set the following values for Manual mode:

Manual operation menu items	Values
Manual mode	ON / OFF
Run timer	0 - 600 (s)
Pause timer	0 - 600 (s)
Reduced output	ON / OFF
Smoke	ON / OFF
Output distance	0 - 255

Manual mode

1.6 DMX CONTROL

When connected to DMX and with Manual mode OFF the MAGICFX® SMOKEBUBBLE BLASTER is controlled with 1 safety address and 4 operational addresses:

DMX Address	Address range
Safety address	1 - 512
Start address (Bubble setting)	1 - 512
Start address + 1 (Smoke setting)	1 - 512
Start address + 2 (Fan speed)	1 - 512
Start address + 3 (Go trigger)	1 - 512

DMX addresses

The safety address cannot be the same as (one of) the operational address(es). Operating of these addresses results in the following:

DMX Address	DMX Value (decimal)		Result
Safety address	0	99	Device disabled
	100	155	Device enabled
	156	255	Device disabled
Start address (Bubble setting)	0	127	50% bubble capacity
	128	255	100% bubble capacity
Start address + 1 (Smoke setting)	0	85	No smoke
	86	170	50% of bubbles contain smoke
	171	255	100% of bubbles contain smoke
Start address + 2 (Fan speed)	0	9	Fan OFF
	10	255	Minimal speed -> Full speed
Start address + 3 (Go trigger)	0	199	Effect OFF
	200	255	Effect ON

Operation of the DMX addresses

When you link multiple machines with DMX, we advise you to use the same safety address for all machines.

⚠ CAUTION

Always plug in a DMX Terminator into the DMX output of the final unit in the control sequence. Using a DMX Terminator improves signal reliability.

1.7 DISPLAY PANEL

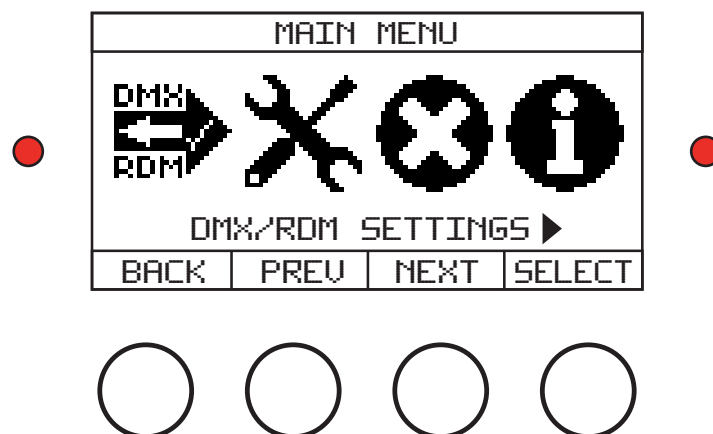

Display panel

The display panel is located on the backside of the MAGICFX® SMOKEBUBBLE BLASTER. Check the following menu structure for all options in the menu. Use the buttons for navigation and selection. The left-hand LED blinks red when DMX is active. The right-hand LED blinks red when an error has occurred.

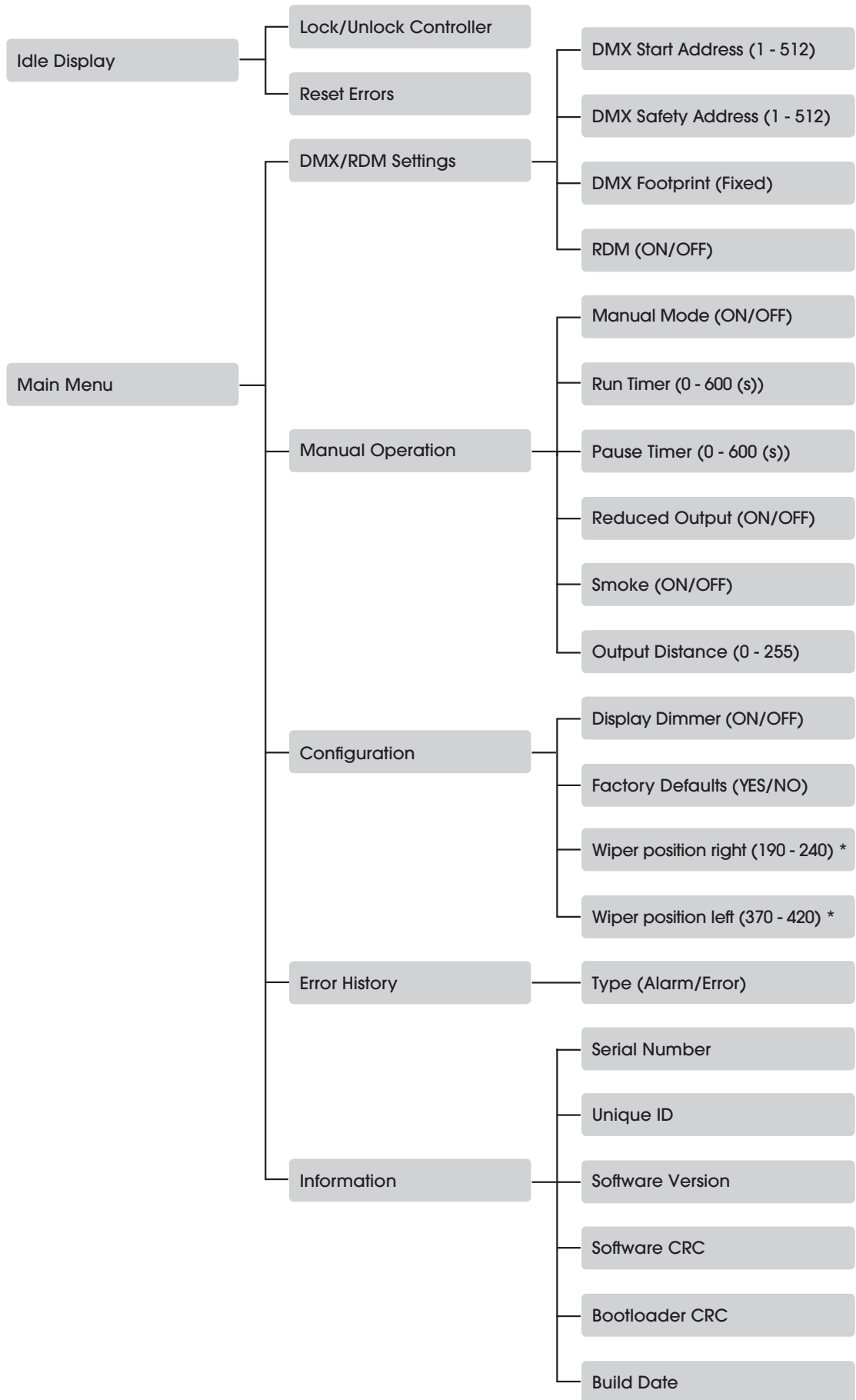

* Only used during production

Menu structure

1.8 RDM CAPABILITY

Remote Device Management Protocol (RDM) is an enhancement of the DMX512 communication protocol. RDM can be used for configuration and status monitoring while DMX512 takes care of the default controlling.

For RDM you will need a RDM compatible controller, cables and a RDM responder like the MAGICFX® SMOKEBUBBLE BLASTER.

The following RDM parameters are supported by the MAGICFX® SMOKEBUBBLE BLASTER.

Parameter ID	Discovery	GET	SET
DISC_UNIQUE_BRANCH	X		
DISC_MUTE	X		
DISC_UN_MUTE	X		
DEVICE_INFO		X	
SUPPORTED_PARAMETERS		X	
SOFTWARE_VERSION_LABEL		X	
DEVICE_MODEL_DESCRIPTION		X	
MANUFACTURER_LABEL		X	
SLOT_DESCRIPTION		X	
DMX_PERSONALITY_DESCRIPTION		X	
DMX_START_ADDRESS		X	X
IDENTIFY_DEVICE		X	X
DEVICE_LABEL		X	X
FACTORY_DEFAULTS		X	X
DMX_PERSONALITY		X	X
RESET_DEVICE			X

RDM parameters

RDM parameters are subject of change due to software updates. Contact MAGIC FX for the latest information and updates.

2 BUBBLE SAFELY!

The MAGICFX® SMOKEBUBBLE BLASTER has been designed and constructed in such a manner that it can be used safely. This applies to the use, the circumstances and the regulations as described in this documentation. Reading this documentation and following the instructions are therefore necessary for everyone who is authorised to work with the MAGICFX® SMOKEBUBBLE BLASTER.

The MAGICFX® SMOKEBUBBLE BLASTER must be placed and used in surroundings that preferably:

- Have a reasonably stable temperature of between 5 and 50°C.
- Have a relative humidity degree of no more than 90% (non condensing).
- Are reasonably free of dust, corrosive gases and high concentrations of organic vapours.
- Are not situated in the vicinity of a source of vibration.

2.1 GENERAL SAFETY RULES

- Only authorised persons may carry out work with the MAGICFX® SMOKEBUBBLE BLASTER.
- Do not use the MAGICFX® SMOKEBUBBLE BLASTER if there are people or animals in the direct output.
- Make sure there are no objects in the direct output that can be damaged by the MAGICFX® SMOKEBUBBLE BLASTER (e.g. by getting wet).
- Make sure that children, unauthorised people and animals do not obtain access to the MAGICFX® SMOKEBUBBLE BLASTER.
- Do not connect more units to a single electrical circuit than the installed fuse is able to handle. (Calculate the summed load with the electrical data from Section 1.2)
- Do not remove any safeguards, safety caps and safety symbols.
- All required safety devices must be in good condition and function properly.
- Ensure sufficient lighting of the surroundings.
- Keep the workplace clean.

2.2 INDOOR USE

The MAGICFX® SMOKEBUBBLE BLASTER is designed for outdoor use and use in well-ventilated indoor spaces.

⚠ WARNING

Do not use the MAGICFX® SMOKEBUBBLE BLASTER in poor ventilated confined spaces. Exposure to high levels of smoke can cause skin irritation and may obscure visibility.

2.3 RIGGING

Please follow the European and national guidelines for safe rigging and trussing.

2.4 SAFETY SYMBOLS

The following safety symbols are present on the MAGICFX® SMOKEBUBBLE BLASTER.

Symbol	Meaning
	Read the manual carefully before use!

Safety symbols

2.5 PRECAUTIONS FOR OPERATION

⚠ WARNING	Using a damaged or an improper installed machine can lead to death, serious injury or property damage. Always inspect the machine thoroughly before operation.
⚠ WARNING	Missing or obscured safety symbols on the machine can lead to death, serious injury or property damage. Make sure all safety symbols are correctly in place and visible, see Section 2.4.
NOTICE	Do not use other fluids than those that are approved and supplied by MAGIC FX, see Section 1.4.
⚠ WARNING	Always follow the instructions as noted on the jerrycans.
⚠ CAUTION	Walk carefully when approaching the machine. The floor can be slippery due to spilled bubble fluids.

3 LET'S BUBBLE!

3.1 INSTALL THE MACHINE

- 1 Bring the cased MAGICFX® SMOKEBUBBLE BLASTER to the desired location.

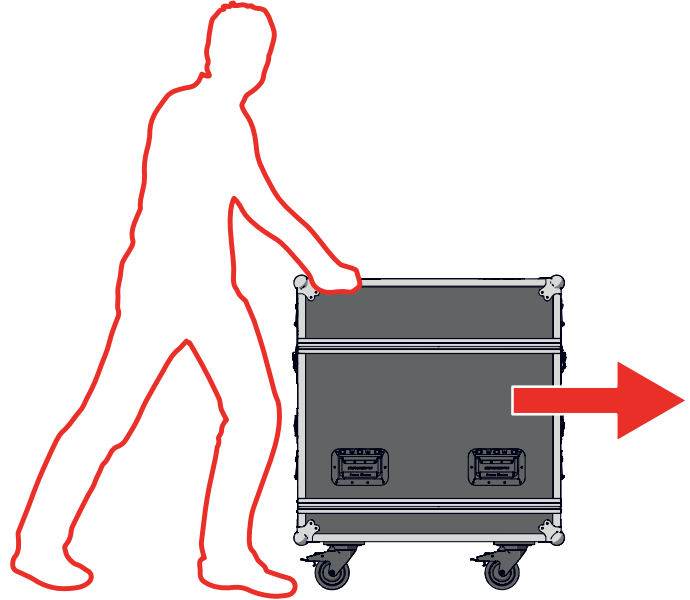

-
- 2 Unlock and remove the top cover.

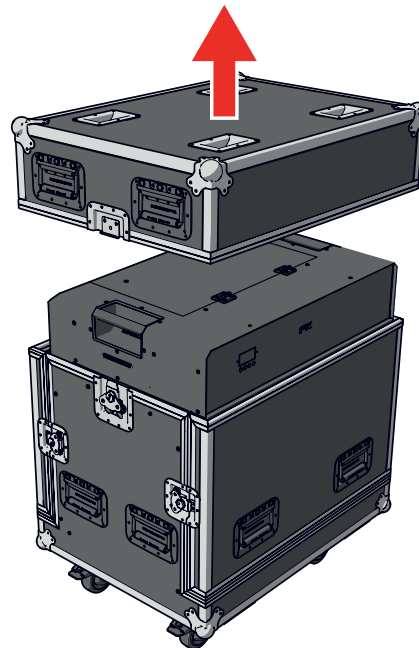

-
- 3** Unlock and remove the side covers.

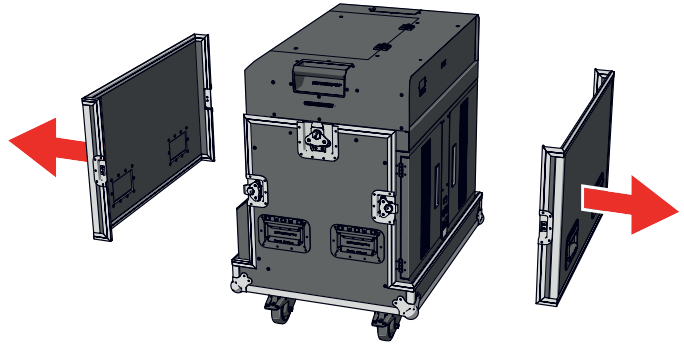

-
- 4** Create a safety zone of 5 m in front of the MAGICFX® SMOKEBUBBLE BLASTER.

The floor can get slippery due to spilled bubble fluid. A safety zone clear of objects is also necessary for an effective output.

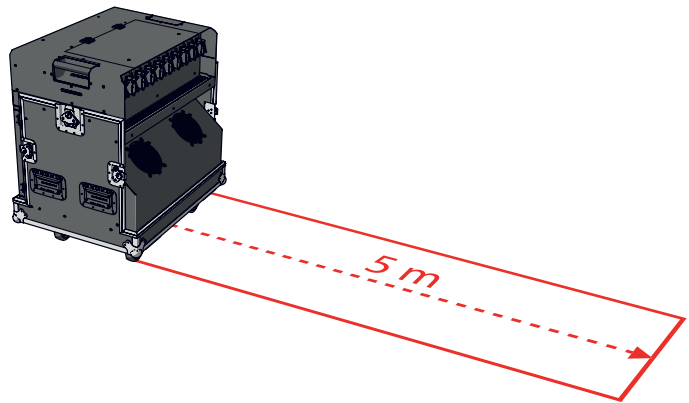

-
- 5** Place the MAGICFX® SMOKEBUBBLE BLASTER in its final position and set the brakes.

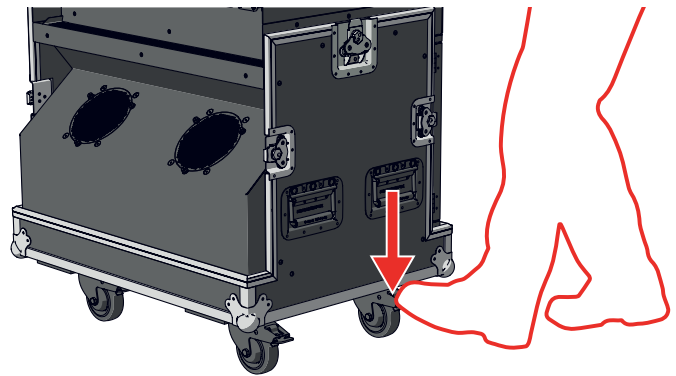

3.2 (RE)PLACE THE JERRYCAN WITH BUBBLE FLUID

NOTICE

Do not use other fluids than those that are approved and supplied by MAGIC FX, see Section 1.4.

⚠ WARNING

Always follow the instructions as noted on the jerrycans.

- 1 Make sure that the machine is not in operation (FX LED indicator is dimmed).



- 2 Open the bubble cabinet door. Disconnect and remove an empty jerrycan if present.

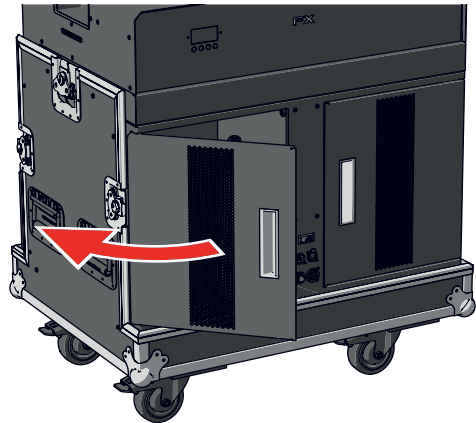

- 3 Place a jerrycan with bubble fluid in the bubble cabinet and remove and save the lid.

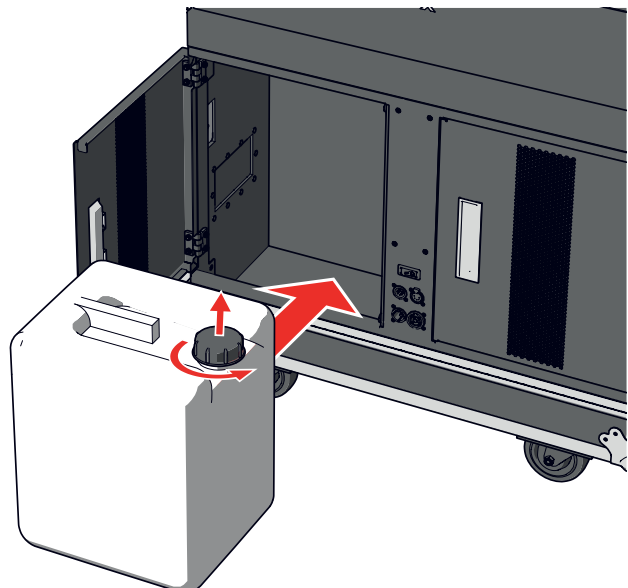

-
- 4 Connect the bubble lid inside the cabinet.

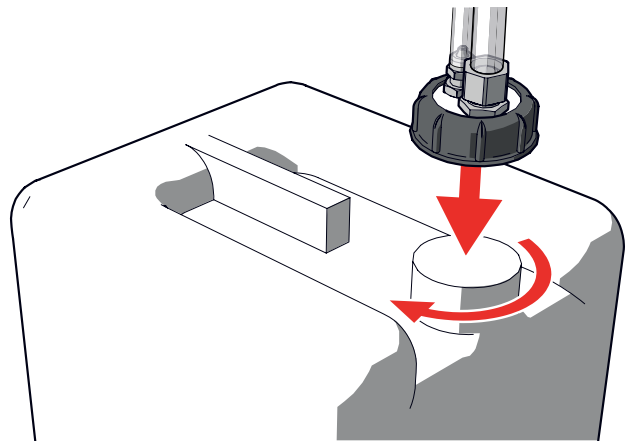

-
- 5 Close the bubble cabinet door.

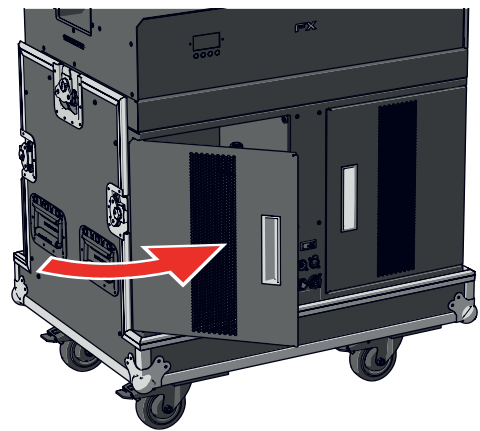

-
- 6 In case of multiple machines: Repeat steps 1-7 for each machine.
-

3.3 (RE)PLACE THE JERRYCAN WITH SMOKE FLUID

NOTICE

Do not use other fluids than those that are approved and supplied by MAGIC FX, see Section 1.4.

WARNING

Always follow the instructions as noted on the jerrycans.

-
- 1 Make sure that the machine is not in operation (FX LED indicator is dimmed).



-
- 2** Open the smoke cabinet door. Disconnect and remove an empty jerrycan if present.

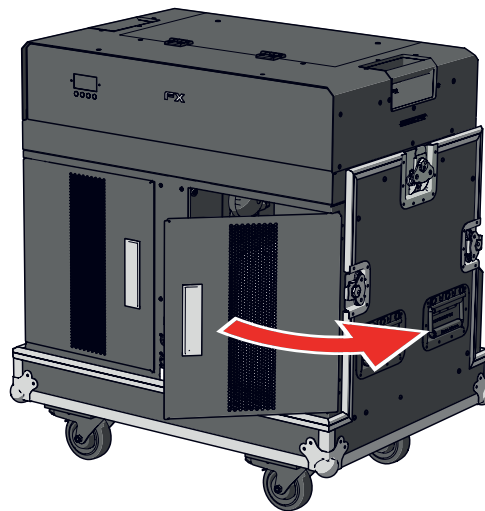

-
- 3** Place a jerrycan with smoke fluid in the smoke cabinet, and remove and save the lid.

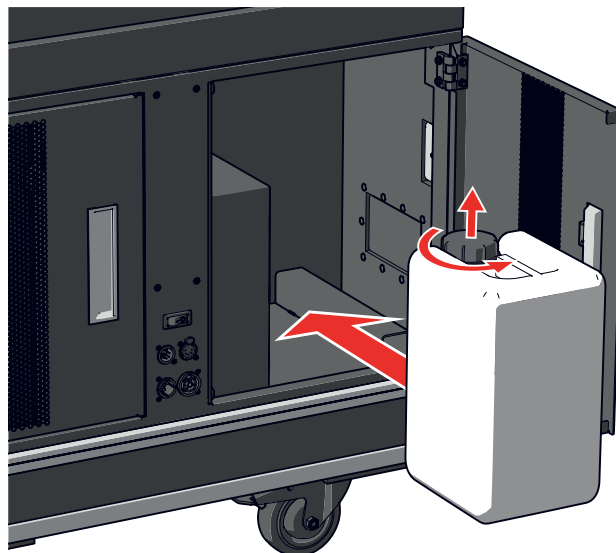

-
- 4** Connect the smoke lid inside the cabinet.

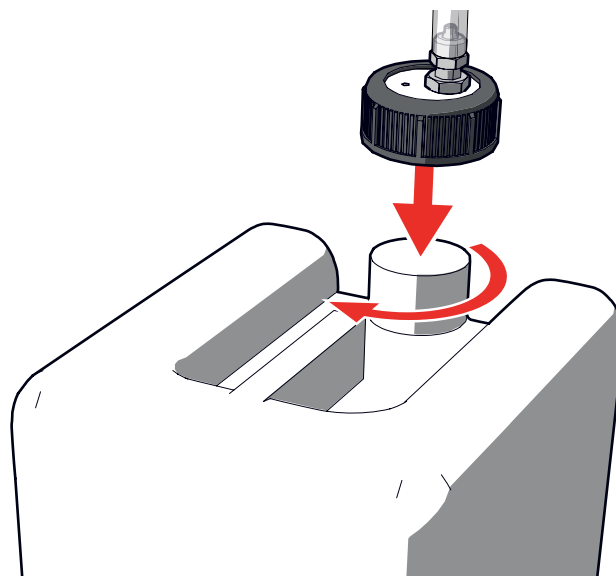

-
- 5 Close the smoke cabinet door.

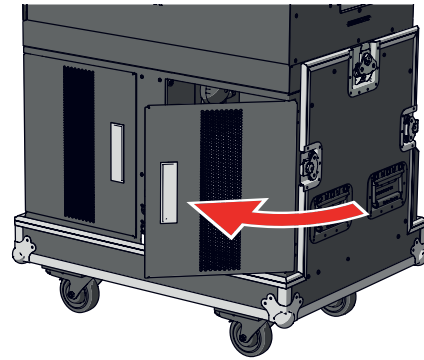

-
- 6 In case of multiple machines: Repeat steps 1-7 for each machine.
-

3.4 CONFIGURE MANUAL MODE

1. Switch the machine ON (If Manual mode is ON, the machine starts bubbling instantly).
2. Use the display and buttons to create the desired output in Manual mode, see Chapter 1.
3. Make sure that Manual mode is ON and switch the machine OFF.

3.5 BUBBLE IN MANUAL MODE

1. Make sure that the prescribed safety zone is free from persons.
2. When it's time to bubble, switch the machine ON.
3. Enjoy the view!

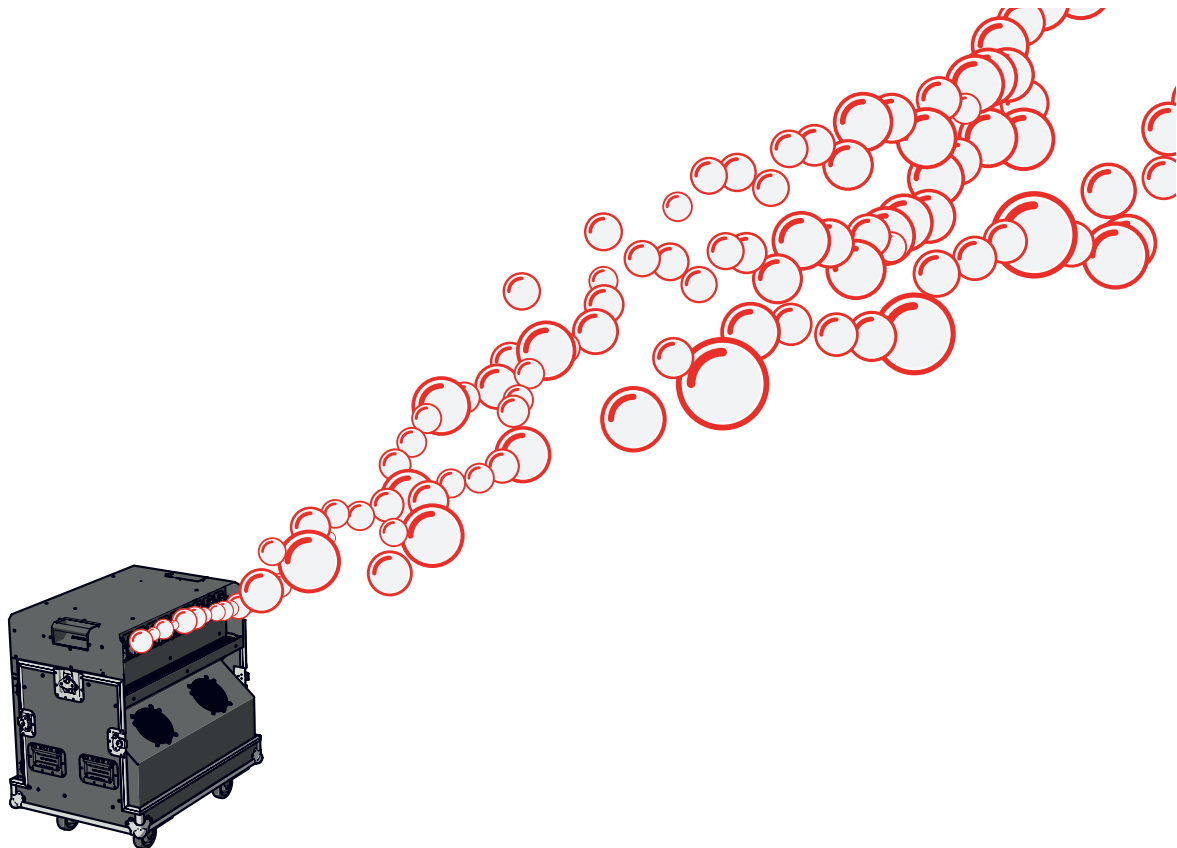

4. To stop blasting bubbles:
 - Set Manual mode to OFF, or;
 - Switch the machine OFF (next time you switch the machine ON, it starts bubbling again instantly).

3.6 CONNECT POWER AND SETUP DMX

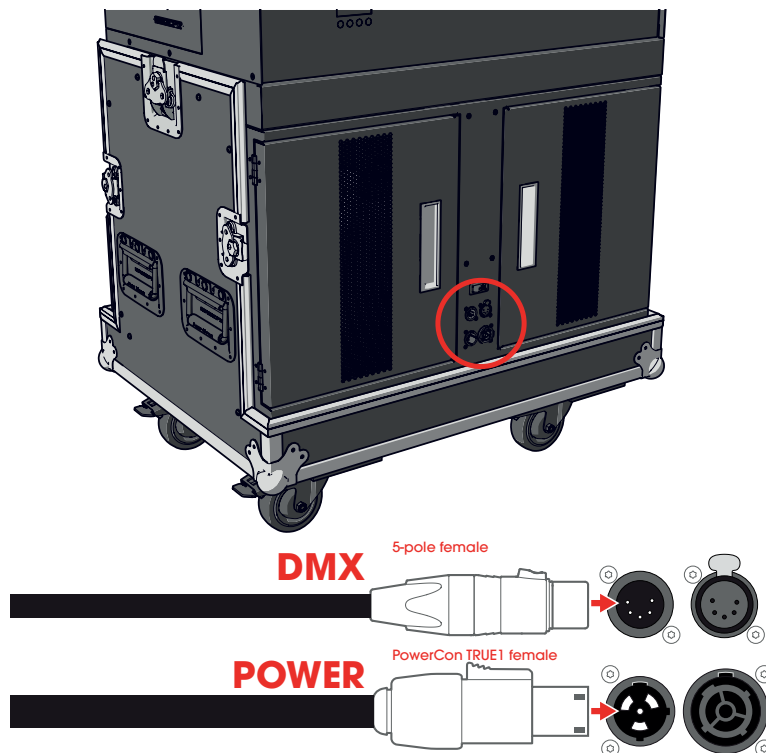

1. Connect a power cable with a Powercon TRUE1 Female connector to the power input.
2. Connect the other end of the power cable to a 220 - 240 Vac (50 Hz) power source.
3. Connect the female connector of a 5-pole DMX cable in the DMX input.
4. Connect the other end of the DMX cable to your DMX controller.
5. Switch the machine ON (If Manual mode is ON, the machine starts bubbling instantly).
6. Make sure that in the menu Manual mode is OFF, see Section 1.7.
7. Use the display and buttons or a RDM controller to assign DMX addresses, see Chapter 1.
8. Optionally see Section 3.7 for adding more machines to the same sequence.

CAUTION

Always plug in a DMX Terminator into the DMX output. Using a DMX Terminator improves signal reliability.

3.7 SETUP MULTIPLE MACHINES IN A SEQUENCE WITH DMX

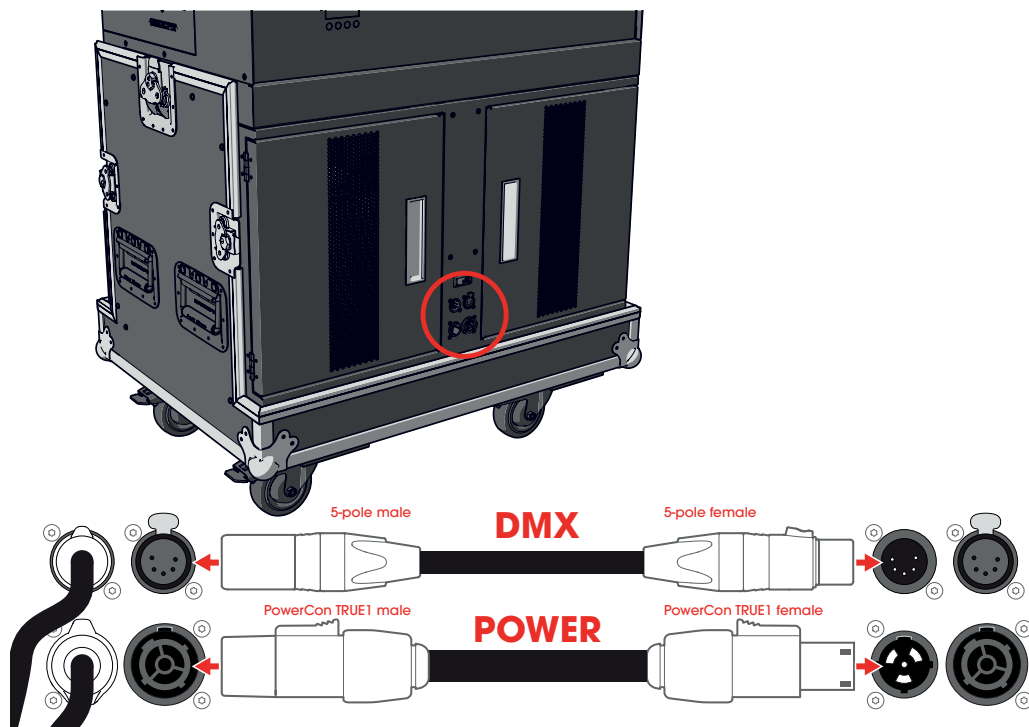

1. Connect a power link cable to the power output.
2. Connect the other end to the power input of the next machine.
3. Connect a DMX cable to the DMX output.
4. Connect the other end to the DMX input of the next machine.
5. Switch the machine ON (If Manual mode is ON, the machine starts bubbling instantly).
6. Make sure that in the menu Manual mode is OFF, see Section 1.7.
7. Use the buttons or a RDM controller to assign DMX addresses, see Chapter 1.
8. Repeat step 1 to 5 for each subsequent machine.

CAUTION

Always plug in a DMX Terminator into the DMX output of the final unit in the control sequence. Using a DMX Terminator improves signal reliability.

3.8 BUBBLE WITH DMX

1. Set the first three operational addresses (bubble setting, smoke setting, fan speed) to define the desired output, see Section 1.6.
2. Make sure that each prescribed safety zone is free from persons.
3. Activate the safety address. The FX LED indicator on each machine lights up and the bubble fluid starts circulating.
4. When it's time to bubble, activate the fourth operational address (Go trigger).
5. Enjoy the view!

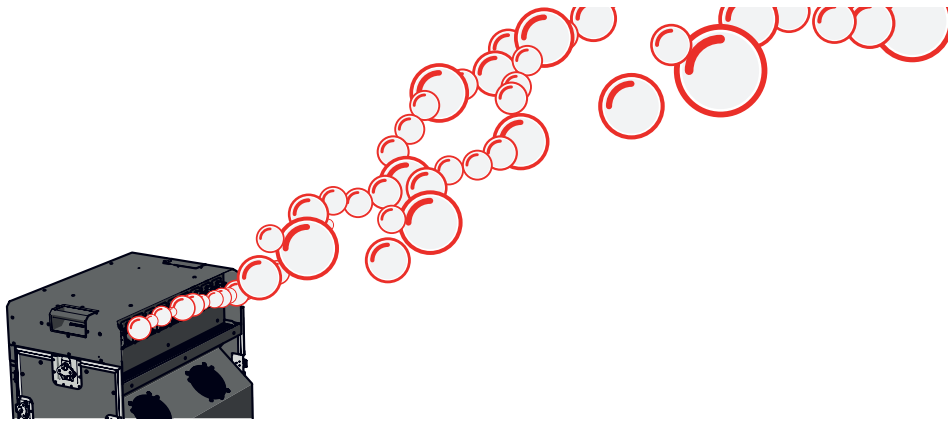

6. Deactivate the fourth operational address (Go trigger) to stop blasting bubbles.
7. Deactivate the safety address. The FX LED indicator on each machine dims and the bubble fluid stops circulating.

3.9 CLEAN UP

⚠ CAUTION

Walk carefully when approaching the machine. The floor can be slippery due to spilled bubble fluids.

- 1 Make sure that the machine is not blasting bubbles.
-

- 2 Open the bubble cabinet door.

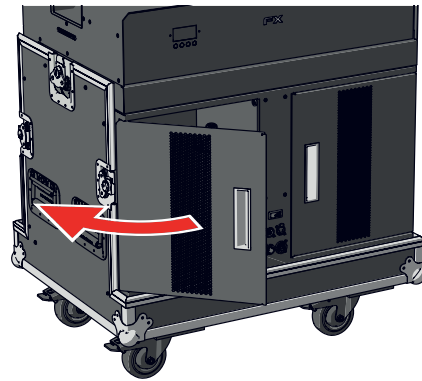

- 3 Disconnect the bubble lid from the jerrycan.

Remove the jerrycan with bubble fluid and close off with the original lid..

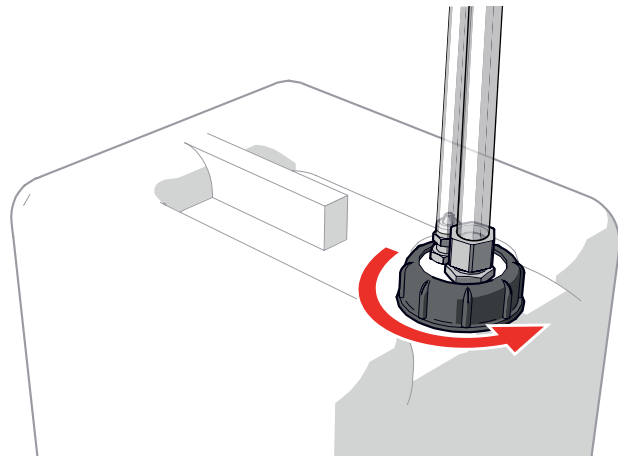

-
- 4 Fill up an empty jerrycan with hand warm water and place it in the bubble cabinet.

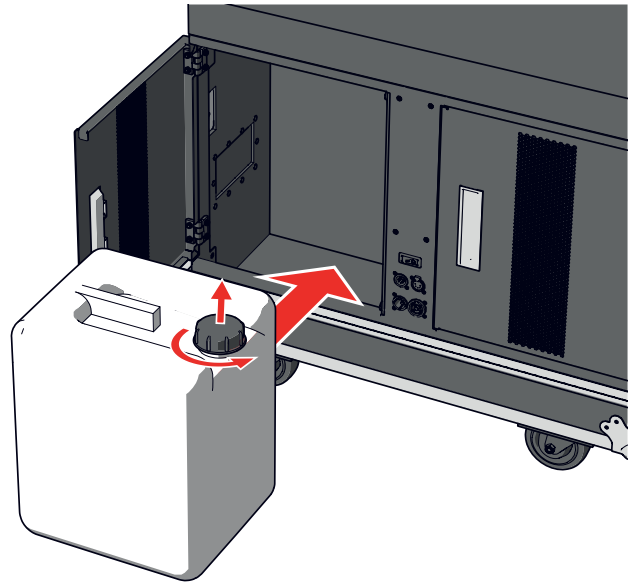

-
- 5 Connect the bubble lid inside the cabinet.

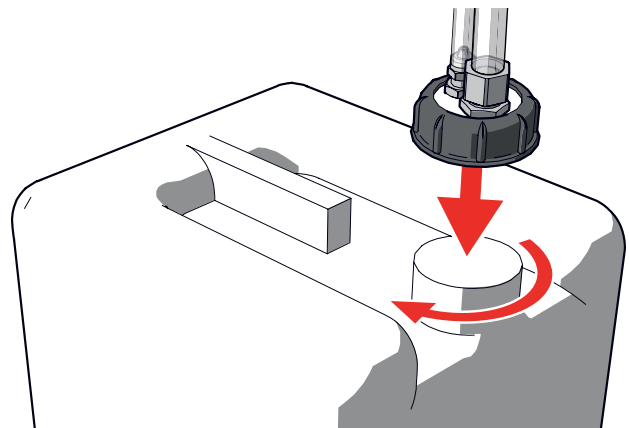

-
- 6 Use the display and buttons to set the Manual mode to the following values:

Manual Mode	ON
Run Timer	600 s
Pause Timer	0 s
Reduced Output	OFF
Smoke	OFF

The machine starts flushing the bubble system with water from the jerrycan.

-
- 7 Wait until the machine does not generate bubbles anymore and only water is coming out of the bubble heads.
-
- 8 Set Manual mode to OFF and switch the machine OFF.
-
- 9 Disconnect all DMX and power cable(s).
-

10 Disconnect and remove the jerrycan.

11 Close the bubble cabinet door.

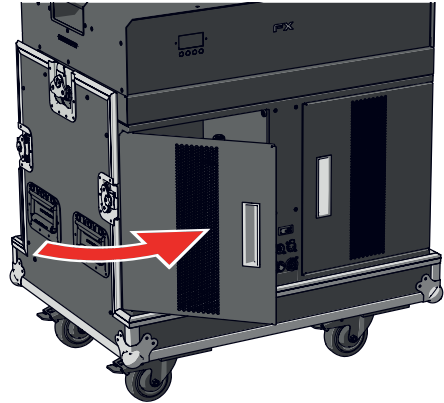

12 Wipe down the machine with hand warm water and a cloth.

13 Clean the floor in front of the machine.

14 Position the wiper of each bubble head to the right side.

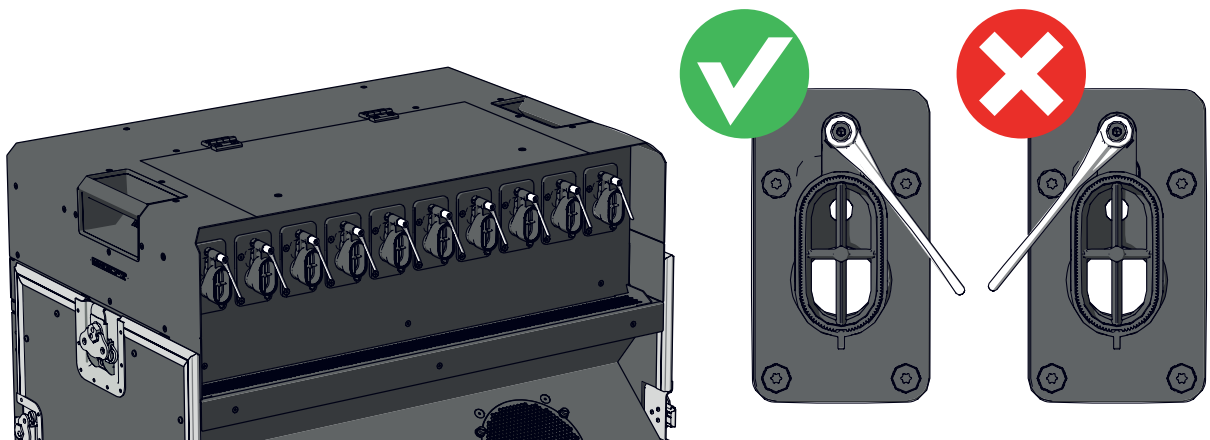

15 Remove each bubble head.

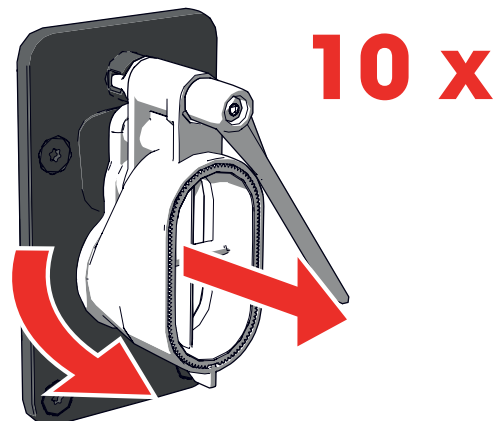

-
- 16** Remove the inner ring from each bubble head.

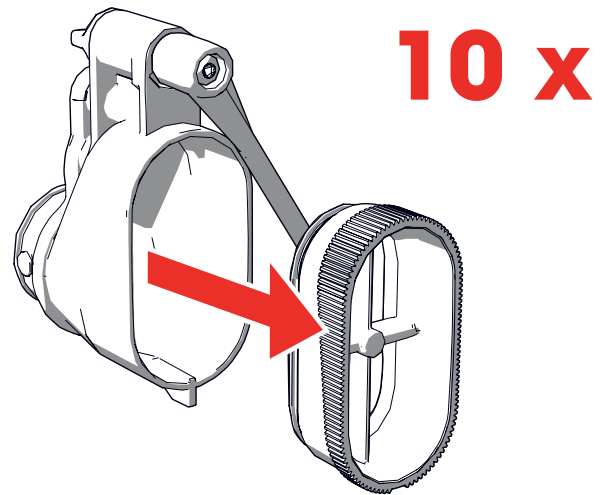

-
- 17** Remove the drip tray and wipe down the drip cabinet with a damp cloth.

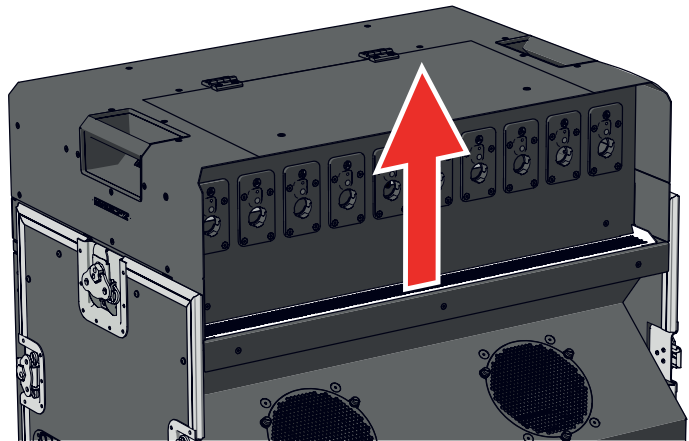

-
- 18** Clean the bubble heads, inner rings and the drip tray with hand warm water.

-
- 19** Replace the drip tray.

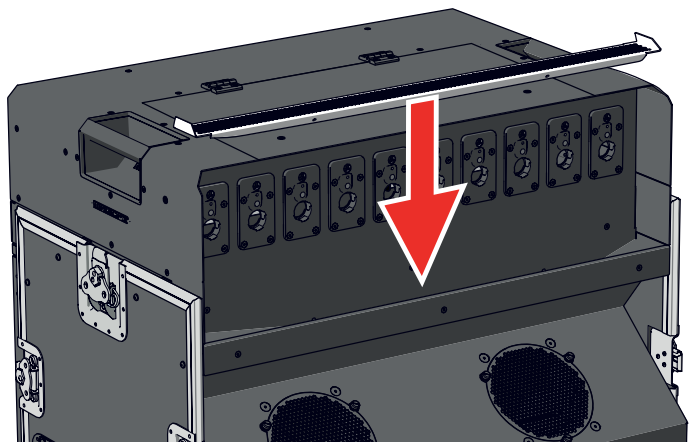

20 Replace the inner ring for each bubble head. Make sure that the inner ring is outlined correctly with the bubble head with the notch down.

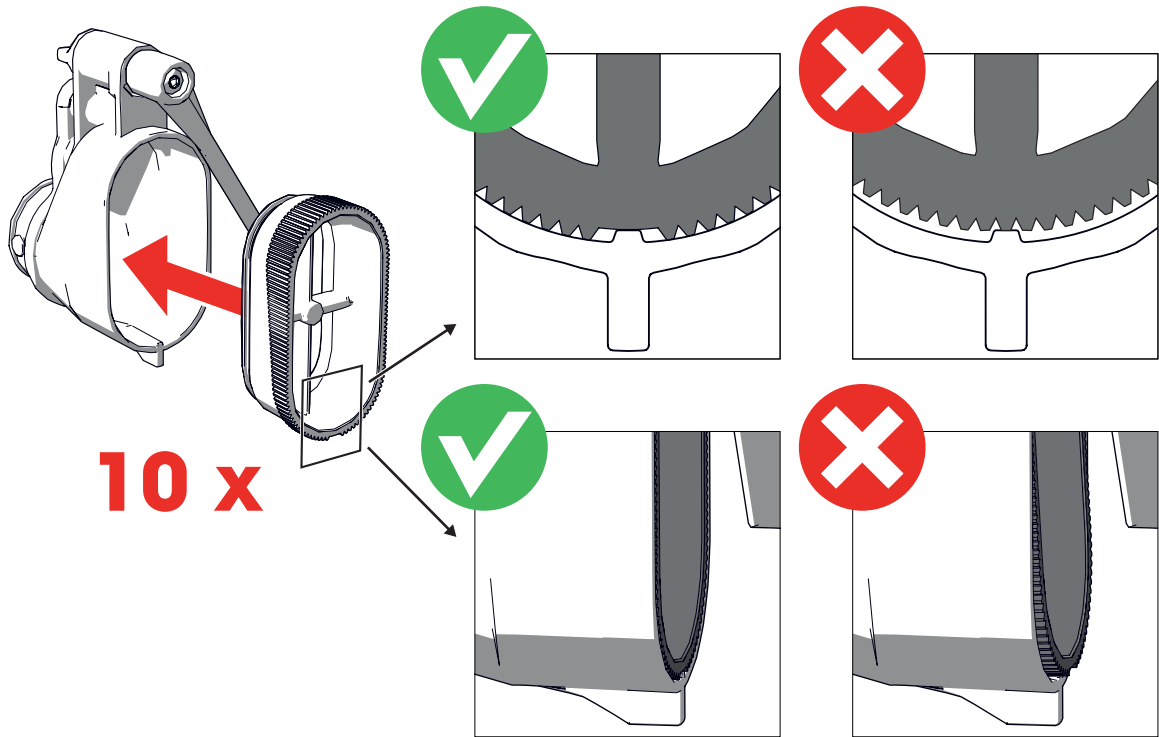

21 Place and turn each bubble head back in place.

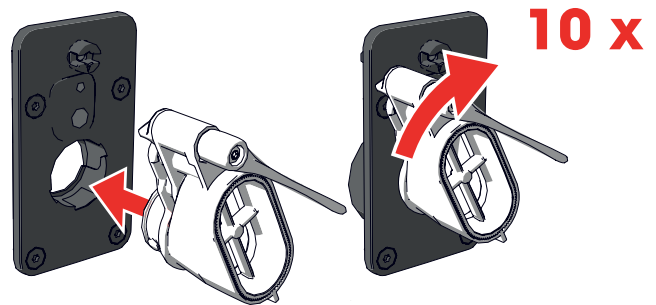

22 Place and lock the side covers.

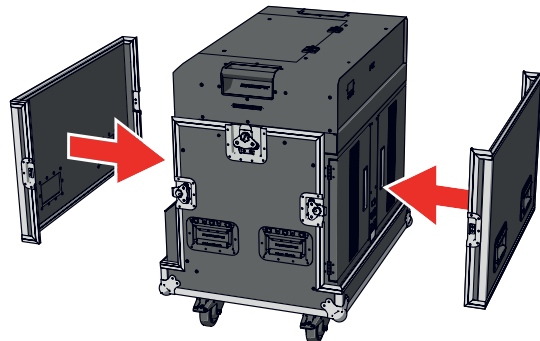

23 Place and lock the top cover.

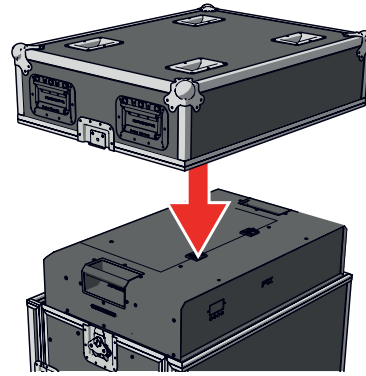

24 Release the brakes.

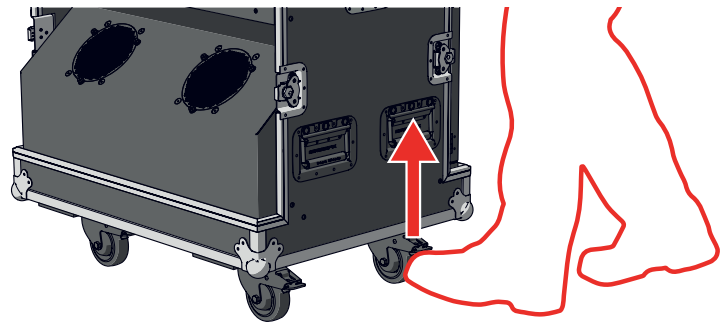

3.10 CLEAN THE LAUNCH FANS (WHEN NEEDED)

1 Make sure that the machine is switched OFF and not connected to a power source.

2 Remove a launch fan cover.

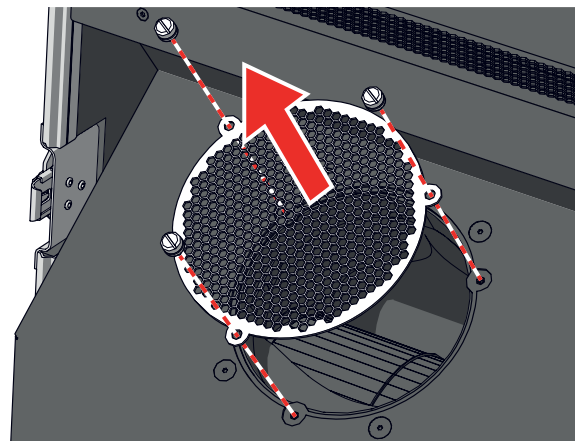

3 Clean the fan interior and the fan blades with a cloth.

4 Place the fan cover and fasten with the screws.

5 Repeat steps 2 to 4 for the other launch fan.

4 MAINTENANCE

To achieve the maximum service life of the MAGICFX® SMOKEBUBBLE BLASTER you must regularly clean the MAGICFX® SMOKEBUBBLE BLASTER and test if it is functioning correctly.

Contact MAGIC FX if the MAGICFX® SMOKEBUBBLE BLASTER is not functioning correctly.

⚠ DANGER

Do not replace parts yourself; always consult MAGIC FX if necessary.

5 TROUBLESHOOTING

Always contact MAGIC FX if any malfunctions or errors occur that cannot be solved with the instructions as described in this manual.

6 CORRECT DISPOSAL



This symbol on the product and / or accompanying documents means that used electrical and electronic products (WEEE) should not be mixed with general household waste. For proper treatment, recovery and recycling, please take this product to designated collection points where it will be accepted free of charge.

Alternatively, in some countries you may be able to return your products to your local retailer upon purchase of an equivalent new product.

Disposing of this product correctly will help save valuable resources and prevent any potential negative effects on human health and the environment, which could otherwise arise from inappropriate waste handling.

Please contact your local authority for further details of your nearest designated collection point.

Penalties may be applicable for incorrect disposal of this waste, in accordance with your national legislation.

7 EC DECLARATION OF CONFORMITY

According to Annex III A Low Voltage Directive 2014/35/EU + Machinery Directive 2006/42/EC

MAGIC FX B.V. declares as manufacturer and composer of the technical construction file that the product with the following specifications:

Name machine : SMOKEBUBBLE BLASTER
Type : MFX1603
Voltage : 220-240Vac 50Hz
Serial number : on product
Year of construction : on product

Is in conformity with the minimal safety regulations as stated in the following directive(s):

- EMC (2014/30/EC) ElectroMagnetic Compatibility
- RoHS (2011/65/EU) Restriction of the use of certain Hazardous Substances
- WEEE (2012/19/EU) Waste Electrical & Electronic Equipment

The following harmonized standards were applied:

- NEN-EN-ISO 12100:2010 Safety of machinery - General principles for design - Risk assessment and risk reduction.
- NEN-EN-IEC 60204-1:2006, Safety of machinery - Electrical equipment of machines - Part 1: General requirements.
- NEN-EN-IEC 61000-6-3:2007/A1:2011, Electromagnetic compatibility (EMC) - Part 6-3: Generic standards - Emission standard for residential, commercial and light-industrial environments.

- Original declaration of conformity
 Translation of the original declaration of conformity

Name manufacturer : MAGIC FX B.V.
Address : Schouwrooij 27, 5281 RE BOXTEL
Country : The Netherlands

CEO : B. Veroude
Date : 22-2-2018

Signature :

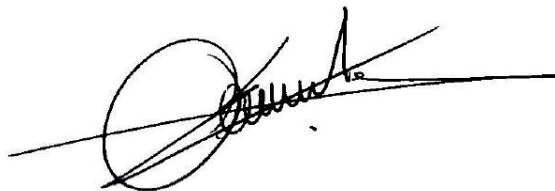

MAG:CFX[®]

WWW.MAGICFX.EU

